

MSI-7300
DYNA-LINK 2

QUALITY TENSION
DYNAMOMETERS



*Compatible with Optional
MSI-8000 RF Remote Display*



**Measurement Systems
International™**

A RICE LAKE WEIGHING SYSTEMS COMPANY

800-874-4320
www.msiscales.com

MSI-7300 DYNA-LINK 2

QUALITY TENSION DYNAMOMETERS

Introducing new and improved performance features

Dyna-Link 2 is lighter and more portable than its predecessor. It interfaces with industry-standard Crosby shackles and a variety of accessories and options, including wireless connectivity with the MSI-8000 RF Remote Display. Long-range viewing is enhanced by a large five-digit, 1.22 inch (31 mm) LCD with resolution settings up to 5,000 divisions and precision accuracy over a wide range of capacities.

Dyna-Link 2 is constructed of high-grade, aircraft-quality aluminum with an anodized finish and gasket sealing to ensure environmental protection to NEMA 4 and IP 65 ratings.

Peak digital processing with low power consumption provides up to 300 hours of operation from standard flashlight batteries. Portable battery-powered display is packaged for industrial use and includes a serial output for interface with data collection and recording devices.

MSI-8000 provides full-function remote control of Dyna-Link 2 features up to distances of 100 ft (30m).



MSI-8000 RF Remote Display

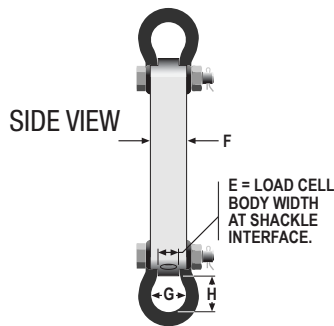
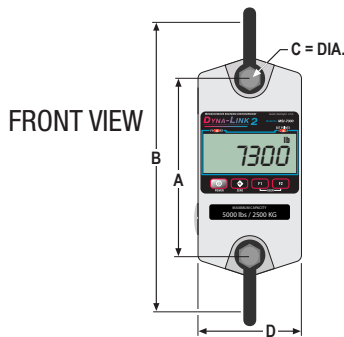

Standard Product Specifications

Accuracy:	0.1% of rated capacity
Display:	Five-digit, 1.22 inch (31 mm) Liquid Crystal
Functions:	On/Off, Zero, Hi-Speed Peak Hold (220 samples/second), Setpoints (2 selectable), Total, Tare, Auto-Off, Motion Filter
LED Annunciators:	Function 1, Function 2, Setpoint 1, Setpoint 2
LCD Annunciators:	Net, Center of Zero, Stable, Battery Test, Peak Hold, Total
Displayable Units:	Pounds, Kilograms, Kilonewtons, Tons, Metric Tons
Data Output:	Serial RS-232
Operating Time:	Up to 150 hours during typical use with "C" and 300 hours in "D" size alkaline battery configuration.*
Power:	2 each "C" alkaline batteries for capacities up to 10,000 lb 2 each "D" alkaline batteries for capacities 25,000 - 100,000 lb
Operating Temperature:	-40° to 158°F (-40° to +70°C)
Material:	2024 aircraft grade aluminum
Enclosure:	NEMA 4 / IP65, anodized corrosion-resistant finish
Overload:	200% Safe / 700% ultimate safety factor up to the 100,000 lb capacity
Calibration:	Digital

MSI-7300 Options and Accessories

- RF Modem Link for Connectivity with MSI-8000
- Enhanced Display Resolution (5000 d)
- Audible Setpoint Alarm
- Crosby Top & Bottom Shackles
- Portable Transport Case
- Serial Output Cable
- Heavy Capacity Configurations (> 50 tons)

Optional MSI-8000 RF Remote Display Features

Functions:	On/Off, Zero, Tare, Peak Hold, Units, Total, High Resolution Net/Gross, Print, Test, Total Remote Devices
Display:	Five-digit, 1.22 inch (31 mm) Liquid Crystal
Annunciators:	Same as MSI-7300 Dyna-Link 2
Power:	Rechargeable Lithium Polymer Battery Operating time between charges is 24 hours, typical 100/240VAC battery charger is included
RF Frequency:	2.4 GHz - 802.15.4. Operating range 100 ft (30 m) typical
Enclosure:	Industrial grade NEMA 4/IP65
Output:	Serial RS-232

*Standard Units only, RF Unit's Battery life 24 hours typical continuous or better.

Capacity	Resolution	A	B	C	D	E	F	G	H	Shipping Weight without Shackles	Optional Crosby Shackles
1,000lb 500kg	.5lb .2kg	8.0in 203mm	13.53in 344mm	.75in 19mm	5in 127mm	.99in 25mm	1.75in 44.5mm	1.69in 43mm	1.75in 44.4mm	8lb 3.6kg	G-2130 3.25T
2500lb 1250kg	1lb .5kg	8.5in 216mm	14.03in 356mm	.75in 19mm	5in 127mm	.99in 25mm	1.75in 44.5mm	1.69in 43mm	1.75in 44.4mm	9lb 4.0kg	G-2130 3.25T
5,000lb 2,500kg	2lb 1kg	8.5in 216mm	14.03in 356mm	.75in 19mm	5in 127mm	.99in 25mm	1.75in 44.5mm	1.69in 43mm	1.75in 44.4mm	9lb 4.0kg	G-2130 3.25T
10,000lb 5,000kg	5lb 2kg	8.5in 216mm	16.14in 410mm	1in 25mm	5.50in 140mm	1.35in 34mm	2.00in 51mm	2.28in 58mm	2.34in 59.4mm	11lb 5.0kg	G-2130 6.5T
25,000lb 12,500kg	10lb 5kg	9.5in 241mm	22.66in 576mm	1.63in 41mm	6.38in 162mm	2.24in 57mm	2.50in 63.5mm	3.88in 99mm	4.69in 119mm	19lb 8.6kg	G-2130 17T
50,000lb 25,000kg	20lb 10kg	9.63in 245mm	25.67in 652mm	2in 51mm	7.50in 191mm	2.74in 70mm	3.25in 82.5mm	5.00in 127mm	5.75in 146mm	29lb 13kg	G-2130 25T
100,000lb 50,000kg	50lb 20kg	12in 305mm	29.75in 756mm	2.25in 57mm	8.13in 207mm	3.11in 79mm	5.25in 133mm	5.75in 146mm	4.81in 122mm	65lb 30kg	G-2140 55T

Consult factory for higher capacities from 80 to 250 tons.



A RICE LAKE WEIGHING SYSTEMS COMPANY



14240 Interurban Avenue South, STE. 200, Seattle, Washington 98168-4661 U.S.A.
TEL: 206-433-0199 • FAX: 206-244-8470 • EMAIL: info@msiscales.com www.msiscales.com

© 2012 by Measurement Systems International, Inc. PN 151211 9/12
Specifications subject to change without notice. Printed in U.S.A.