



# SJX Carat and Gold Series

Portable Balances



## *A Dynamic Weighing Experience with the Next Generation of OHAUS Carat and Gold Portable Balances*

Designed for a wide range of Legal-for-Trade applications, the Class II and Class III certified SJX Carat and Gold balances are ideal for weighing jewelry, precious metals and gemstones. Equipped with superior overload protection, large backlit display, fast stabilization time, multiple weighing units, application modes and connectivity options, these slim balances offer a truly user-friendly weighing experience.

### *Standard Features Include:*

- **Geared for the Job with Legal-for-Trade Approvals & Superior Overload Protection**  
Scout meets Class II and III accuracy requirements for countertop retail applications. Integrated superior overload protection system protects the balance from damage ensuring durability in everyday applications.
- **Large Backlit LCD Clearly Shows Weighing Results in Retail Applications**  
The Scout SJX is equipped with a bright white backlit display which shows the net weight of precious metals and stones clearly. An optional auxiliary display can also be installed.
- **Fast Weighing Speed and High Resolution Deliver Repeatable and Reliable Results**  
Stabilization time as fast as 1 second means quick results and increased efficiency. Equipped with superior weighing technology, the Scout also ensures repeatable and reliable weighing results.
- **Multiple Connectivity Options Available for Data Logging and Communication**  
With expanded connectivity options including RS232, USB Host, USB Device, Ethernet and Bluetooth®, the Scout provides added versatility to data logging and communication.

# SJX Carat and Gold Series Portable Balances

## Legal-for-Trade Approvals

NTEP and Measurement Canada approved models meet or exceed Class II or III accuracy requirements, making the Scout ideal for commercial applications where reliability and precision are essential.



## Superior Protective Features

The superior mechanical overload protection system of the Scout is comprised of a high-strength stainless steel pan and an impact-resistant plastic pan support. This enables the balance to safely withstand loads up to 10 times its rated capacity.



## Clear Viewing of Results

The large backlit LCD provides operators a clear view of their weighing results. An optional auxiliary display can also be installed easily to provide additional weight notifications to customers in retail environments.



## Improved Performance

Stabilization time as fast as 1 second and high resolution load cell with up to 150,000d resolution and readability to 0.001g, deliver extremely quick, precise and repeatable weighing results.

## Expanded Connectivity Options

Scout has multiple connectivity options for convenient data logging and communication, as well as connecting to an auxiliary display. Options include - RS232, USB Host, USB Device, Ethernet and Bluetooth®. With the USB Host option, you can simply save and transfer data from the balance to a USB drive. The Bluetooth option allows you to wirelessly operate the balance via a mobile device or tablet for Android™.

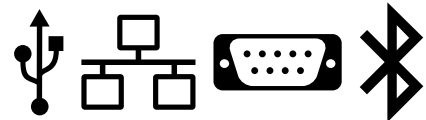

## Draftshield Model Available

Scout's ingenious draftshield (1mg model only) was designed with an easy to remove top cover piece. This serves as a wind protection ring which keeps the weighing surface stable in drafty environments, while maintaining weighing speed.



## Built-in Application Modes

- **Weighing**—Determines the weight of items on the pan in the selected unit of measure.
- **Parts Counting**—Counts the number of pieces on the pan using a uniform weight.
- **Percent Weighing**—Measures the weight of a sample displayed as a percentage of a pre-established reference weight.
- **Check Weighing**—Compares the weight of a sample against target limits.
- **Totalization**—Measures cumulative weight of multiple items. Cumulative total may exceed balance capacity.
- **Density Determination**—Determines density of solids or liquid. With the integrated weigh below hook, it is possible to perform specific gravity tests for objects that cannot be easily placed on the weighing pan.
- **Display Hold**—Manually holds the last stable weight or the first highest stable weighing value on the display.

The Bluetooth® word mark and logos are registered trademarks owned by Bluetooth SIG, Inc. and any use of such marks by OHAUS is under license. Android is a trademark of Google Inc.



**Draftshield**  
Protects the sample from external influences, increasing the speed and repeatability of measurements



**Lockswitch**  
The Scout can be locked into a specific configuration using the lockswitch



**Connectivity**  
Expanded connectivity options including RS232, USB Host, USB Device, Ethernet and Bluetooth®



**Security Slot**  
Integrated security slot prevents theft



**Large Backlit LCD**  
High contrast LCD Display shows weight and application data clearly- even in poor lighting conditions



**Weigh Below Hook**  
The weigh below hook on the bottom of the Scout allows for density determination or specific gravity calculations

## Outline Dimensions

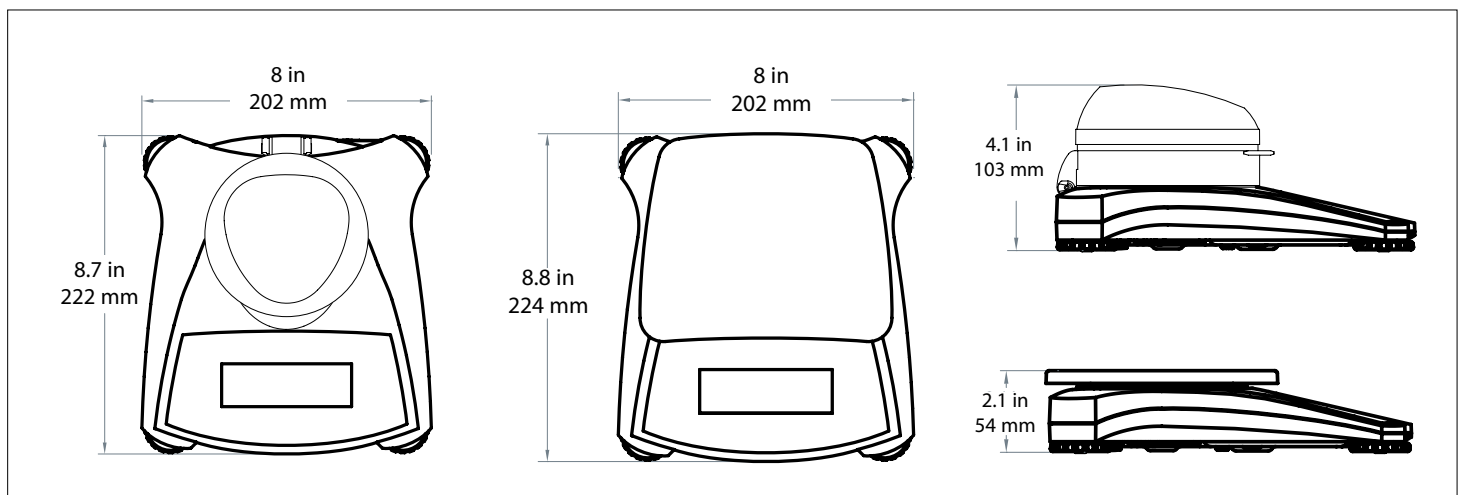

# SJX Carat and Gold Series Portable Balances

Approved Model	SJX323N/E		SJX622N/E		SJX1502N/E		SJX6201N/E	
	Legal for trade	Non-legal for trade	Legal for trade	Non-legal for trade	Legal for trade	Non-legal for trade	Legal for trade	Non-legal for trade
Capacity	320 ct (64 g)	320 ct (64 g)	620 g	620 g	1500 g	1500 g	6200 g	6200 g
Readability	0.01 ct (0.001 g)	0.005 ct (0.001 g)	0.1 g	0.01 g	0.01 g	0.01 g	1 g	0.1 g
Verification Interval e	0.1 ct (0.01 g)	—	0.1 g	—	0.1 g	—	1 g	—
Class	II	—	III	—	II	—	III	—
Capacity x Readability (kg)	—	—	—	—	1.5 x 0.00001	1.5 x 0.00001	6.2 x 0.001	6.2 x 0.0001
Capacity x Readability (ct)	320 x 0.01	320 x 0.005	3100 x 0.5	3100 x 0.05	7500 x 0.5	7500 x 0.05	31000 x 5	31000 x 0.5
Capacity x Readability (oz)	2.26 x 0.0005	2.26 x 0.00005	21.87 x 0.005	21.87 x 0.0005	52.9 x 0.005	52.9 x 0.0005	218.70 x 0.05	218.700 x 0.005
Capacity x Readability (ozt)	2.06 x 0.0005	2.06 x 0.00005	19.93 x 0.005	19.93 x 0.0005	48.2 x 0.005	48.2 x 0.0005	199.3 x 0.05	199.3 x 0.005
Capacity x Readability (dwt)	41 x 0.001	41 x 0.001	398 x 0.1	398 x 0.01	964.5 x 0.01	964.5 x 0.01	3986 x 1	3986 x 0.1
Capacity x Readability (lb)	—	—	1.367 x 0.0005	1.367 x 0.00005	3.3 x 0.0005	3.3 x 0.00005	13.670 x 0.005	13.6685 x 0.0005
Capacity x Readability (grn)	987 x 0.2	987 x 0.02	9568 x 2	9568 x 0.2	23148 x 2	23148 x 0.2	95680 x 20	95680 x 2
Span Calibration Mass <sup>1</sup>	50 g		300 g		1.5 kg		5 kg	
Linearity Calibration Mass	30, 60 g		300, 600 g		1 kg, 1.5 kg		3 kg, 6 kg	
Stabilization Time (s)	1.5		1		1.5		1	
Construction	ABS housing & stainless steel pan							
Draftshield	Yes			No				
Calibration	User-selectable external span or linearity calibration							
Tare Range	Full capacity by subtraction							
Weighing Units <sup>2</sup>	g, kg, ct, oz, ozt, dwt, lb, grn							
Application Modes <sup>2</sup>	Weighing, Parts Counting, Percent Weighing, Check Weighing, Totalization, Density Determination, Display Hold							
Typical Battery Life	80 hours							
Power Requirement	AC adapter(included) or 4 AA batteries(not included)							
Specified Temperature Range	Class II: 10°C (50°F) to 30°C (86°F) at 10% to 80% relative humidity, non-condensing Class III: 10°C (50°F) to 40°C (104°F) at 10% to 80% relative humidity, non-condensing							
Storage Conditions	-20°C (-4°F) to 55°C (131°F) at 10% to 90% relative humidity, non-condensing							
Communication	RS232, USB Host, USB Device, Ethernet or Bluetooth (available as accessories)							
Display Type	Backlit LCD: 6-digit 7-segment with white LED backlight							
Display Size	0.78 in / 20 mm digits							
Pan Size (W x D)	Ø3.7 in / Ø93 mm		Ø4.7 in / Ø120 mm		6.7 x 5.5 in / 170 x 140 mm			
Balance Dimensions (W x D x H)	8 x 8.7 x 4.1 in 202 x 222 x 103 mm			8 x 8.8 x 2.1 in 202 x 224 x 54 mm				
Shipping Dimensions (W x D x H)	11.8 x 9.8 x 5.1 in 300 x 250 x 129mm			11.8 x 9.8 x 3.4 in 300 x 250 x 86 mm				
Net Weight	2.2 lb / 1 kg							
Shipping Weight	3.3 lb / 1.5 kg							

<sup>1</sup> Span calibration weight and scoop are included with 64g model.

<sup>2</sup> Available Weighing Units and Application Modes vary by local regulations.

## Other Standard Features and Equipment

Transportation lock, stainless steel pan, menu & calibration lockout switch, slip-resistant and adjustable feet, leveling bubble, mechanical and software overload/underload protection, stability indicator, auto tare, low battery indicator, auto shut-off, user-selectable printing options, user-selectable communication settings

## Compliance

- **Metrology:** NIST Handbook 44 (NTEP CC 16-015); Measurement Canada Weights and Measures Regulations (NoA AM-6008)
- **Product Safety:** IEC/EN 61010-1; CAN/CSA C22.2 No. 61010-1; UL Std. No. 61010-1
- **Electromagnetic Compatibility:** IEC/EN 61326-1 Class B, Basic environments; FCC Part 15 Class B; Industry Canada ICES-003 Class B

## Accessories

RS232 Interface Kit .....	30268982	Printer, Impact, SF40A, AM .....	30064203
USB Host Interface Kit .....	30268983	Auxiliary display, TAD7-S .....	30333960
USB Device Interface Kit .....	30268984	Security Device .....	80850043
Ethernet Interface Kit .....	30268986	Top Loading Kit for Density Determination .....	30269020
Stacking & Storage Cover (6 pcs) .....	30268987	Carrying Case .....	30269021
Stacking & Storage Cover (1 pc) .....	30268988	In-use Cover .....	30269022

## OHAUS CORPORATION

\* 7 Campus Drive  
Suite 310  
Parsippany, NJ 07054 USA

Tel: 800.672.7722  
973.377.9000  
Fax: 973.944.7177

[www.ohaus.com](http://www.ohaus.com)

With offices throughout  
Europe Asia and  
Latin America

\*ISO 9001:2008

Registered Quality  
Management System

