



# MB27

Moisture Analyzer



## ***Ideal for routine moisture analysis requiring precise results.***

The new OHAUS MB27 Basic Moisture Analyzer combines high quality and durable construction into a sleek, compact design. The MB27 offers dependable, accurate results for a wide variety of moisture analysis applications.

### ***Standard Features Include:***

- **Flexible Performance**

The MB27 provides accurate results at 0.01% (0.001g). With a large capacity of 90 grams, it is ideal for food, agriculture, chemical, pharmaceutical and other applications that require measurements up to 0.01% (0.001g).

- **Simple to Operate**

Set up and operation is extremely easy. Just press and hold buttons to set drying parameters. The MB27 is ideal for routine tasks performed by operators of all skill levels.

- **Compact, Easy-to-Clean Design**

The compact footprint (17 × 14 × 28 cm) of the OHAUS MB27 is designed to take up less space. The easy-to-clean heating chamber is ideal for frequent use and inexpensive maintenance.

# MB27 Moisture Analyzer

Model	MB27
Capacity	90 g
Repeatability (Std Dev ) (g)	0.2% (3 g sample) 0.05% (10 g sample)
Readability	0.01%/0.001 g
Sample size	3g to 20g typical, 0.5g min.
Interface	Bidirectional RS232
Timer	1-99 minutes, 30-second increments to 60 minutes
Heating Technology	Halogen
Temperature Range	50 °C to 160 °C in 5 °C increments
Power	100 to 240 VAC, 50/60 Hz
Tare Range	To capacity by subtraction
Operating Temperature Range	41 °F to 104 °F/5 °C to 40 °C
Display Type	Backlit LCD
Displays	%moisture or %solids or weight (g), temperature, time
Pan Size (Diameter)	3.5 in/90 mm
Dimensions (W × H × D)	6.5 × 5 × 11 in/17 × 14 × 28 cm
Net Weight	5 lb/2.3 kg
Shipping Weight	8.5 lb/3.9 kg

## Compliance

- **Product Safety:** CAN/CSA C22.2 61010-1, CAN/CSA C22.2 61010-2-010, UL 61010-1,
- **Electromagnetic Compatibility:** FCC Part 15 Class A, ICES-003 Class A,

## Accessories

Temperature Calibration Kit, MB Series .....	11113857
Anti-Theft Device .....	80850043
Aluminum Sample Pans, 80 Pcs. ....	80850086
Pads, Glass Fiber, Qty 200 Pcs .....	80850087
In-Use-Cover .....	80252475
Pan Holder, MB Series .....	80252476
Sample Cage, MB Series .....	80252477
Reusable Sample Pans, 3 Pcs, 7mm, MB Series .....	80252478
Reusable Sample Pans, 3 Pcs, 14mm, MB Series .....	80252479
Impact Printer SF40A .....	30064203
Thermal Printer, STP-103, US .....	80251992

## Outline Dimensions

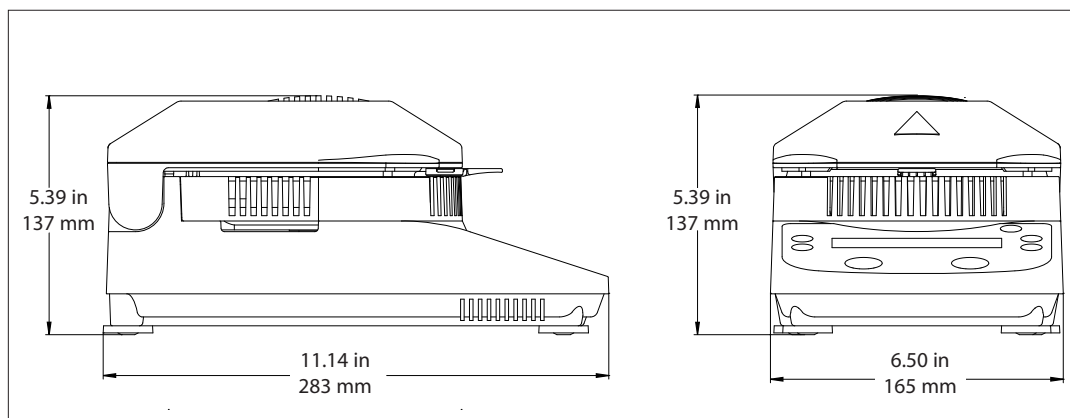

**OHAUS CORPORATION**  
\* 7 Campus Drive  
Suite 310  
Parsippany, NJ 07054 USA

Tel: 800.672.7722  
973.377.9000  
Fax: 973.944.7177

[www.ohaus.com](http://www.ohaus.com)

*With offices throughout  
Europe, Asia, and  
Latin America*

\*ISO 9001:2008  
Registered Quality  
Management System

