

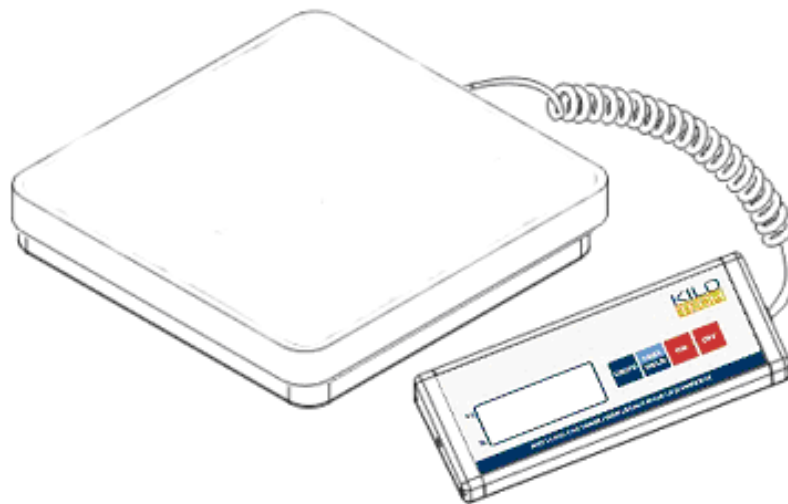

**MODEL KPS 25-2
KPS 50-2
KPS 100-2
KPS 150-2
DIGITAL BENCH SCALE
Operation Manual**



Rev A

KILOTECH
3245 J.B. Deschamps Blvd.,
Montreal, QC H8T 3E4

Phone : 1-514-420-6020
email : kilotech@kilotech.com

Fax : 1-514-420-6022
web : <http://www.kilotech.com>

INTRODUCTION

The Model KPS-2 series is a Digital Bench Scale. That can be powered by battery or AC adapter (included). The scale is equipped with a movable display that can be placed on the work surface or mounted to the wall.

FCC COMPLIANCE STATEMENT

WARNING! This equipment generates, uses and can radiate radio frequency and if not installed and used in accordance with the instruction manual, may cause interference to radio communications. It has been tested and found to comply with the limits for a Class A computing device pursuant to Subpart J of Part 15 of FCC rules, which are designed to provide reasonable protection against such interference when operated in a commercial environment. Operation of this equipment in a residential area may cause interference in which case the user will be responsible to take whatever measures necessary to correct the interference.

You may find the booklet "How to Identify and Resolve Radio TV Interference Problems" prepared by the Federal Communications Commission helpful. It is available from the U.S. Government Printing Office, Washington, D.C. 20402. Stock No. 001-000-00315-4.

All rights reserved. Reproduction or use, without expressed written permission, of editorial or pictorial content, in any manner, is prohibited. No patent liability is assumed with respect to the use of the information contained herein. While every precaution has been taken in the preparation of this manual, the Seller assumes no responsibility for errors or omissions. Neither is any liability assumed for damages resulting from use of the information contained herein. All instructions and diagrams have been checked for accuracy and ease of application; however, success and safety in working with tools depend to a great extent upon the individual accuracy, skill and caution. For this reason the Seller is not able to guarantee the result of any procedure contained herein. Nor can they assume responsibility for any damage to property or injury to persons occasioned from the procedures. Persons engaging the procedures do so entirely at their own risk.

Serial Number _____
Date of Purchase _____
Purchased Form _____

RETAIN THIS INFORMATION FOR FUTURE USE

TABLE OF CONTENTS

Description of Parts	2
Main Features	2
Before You Begin	2
Battery Installation	2
Auto Shut-Off Feature	2
Mounting the Unit	3
Display and Function	3
General Operation	3
Power On / Weighing / Tare Operation / Tare Capability	3
Error and Status Messages	4

SPECIFICATIONS

Capacity (KG): KPS 25-2= 25kg x 0.01kg
KPS 50-2= 50kg x 0.02kg
KPS 100-2=100kg x 0.05kg
KPS 150-2=150kg x 0.1kg

Capacity (LB): KPS 25-2= 55lb x 0.02lb
KPS 50-2= 110lb x 0.05lb
KPS 100-2=220lb x 0.1lb
KPS 150-2=330lb x 0.2lb

Capacity (OZ): KPS 25-2= 880 oz x 0.5 oz
KPS 50-2= 1760 oz x 1oz
KPS 100-2= 3520 oz x 2oz
KPS 150-2= 5280 oz x 5oz

Power Source: 6 AA batteries (not included)
with automatic shut-off *OR* included UL listed
120V AC 60Hz to 9V DC 300mA adapter

PRECAUTIONS

Before using this instrument, read this manual and pay special attention to all "WARNING" symbols:



IMPORTANT



ELECTRICAL
WARNING

Congratulations on your purchase of the Digital Bench Scale. Your Digital Bench Scale is an example of superior design and craftsmanship. In order to optimize its function, be sure to read this instruction manual carefully before use. Keep instructions handy for future reference.

Description of Parts

Model KPS-2 Series

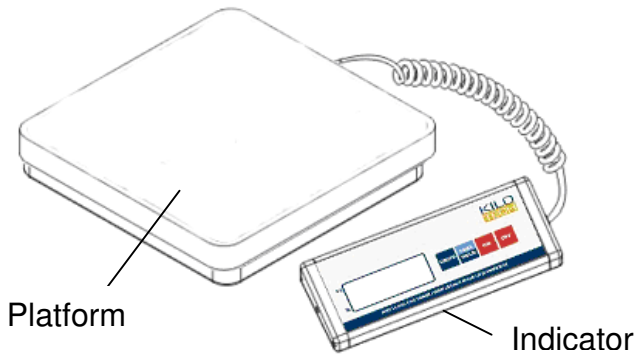

Main Features

- **LCD Display**
1" digit size displays weight.
- **Hold Button**
Press HOLD key, the arrow in the left bottom flashes.
When the loaded weight is above 1.5 kg and stable, the arrow stops flashing. To disable the hold function, press HOLD key again, and the arrow disappears.
- **Units Button**
Press UNIT to toggle between kg, lb and oz.
- **ON/ZERO/OFF Button**
Turn the scale on, zero or off. (The scale will zero when the weight is 20% of maximum capacity).
- **TARE Button**
When there is load on the scale, press this key to return to zero.
Put a container on the scale, press the key to tare the weight, and the tarred value is stored. Then scale is under NET mode.
- **Auto Shut Off**
Powers off after 2 minutes of nonuse.
- **Interface**
The scale contains a one-way RS-232 interface via a 9-pin cable (included with each scale) for transmission of weight and error messages.

See Appendix A for Communication Protocol details.

Before You Begin

1. Remove scale from its box along with control panel and the 120V Adapter.

If using the 120V Adapter, plug one end into the receptacle (connector) at the rear of the scale. Insert the other end (the adapter) into a 120V outlet

Battery Installation

The Digital Bench Scale operates with (6) "AA" batteries (Alkaline preferred).

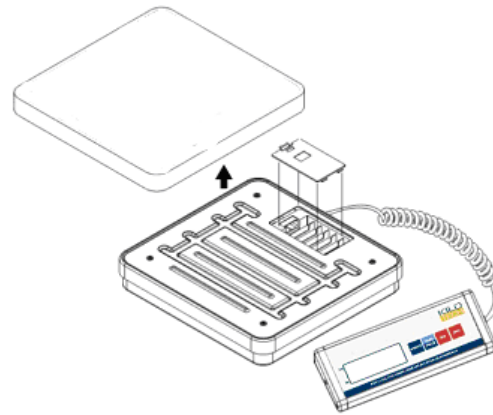

1. Place unit upright on a flat surface and lift platform from top of scale.
2. Remove battery compartment door and insert batteries into compartment. Make certain to observe the correct polarity.
3. Replace compartment door and platform cover on scale.

Auto Shut-off Feature

This feature makes the scale shut-off after 2 minutes of nonuse to conserve the battery. You can disable this feature and the scale will operate continuously.

1. Press and hold TARE until display shows SET <approximately three seconds>.
2. Release TARE, display shows UNIT.
3. Press UNIT to move across to the A.OFF
4. Press HOLD to select an option and save.

To exit the setup menu and save your changes:
Press UNIT until you see END

Press HOLD to save your changes and return to weighing mode.

Mounting the Unit

1. Mount bracket to wall using (2) screws that are appropriate anchors for the surface being mounted to.
2. Lower control panel into mounted bracket. Insert flat tip screws (included) through round holes in mounting bracket and drive the screws into existing threaded holes in lower half of control panel to secure control panel to bracket.

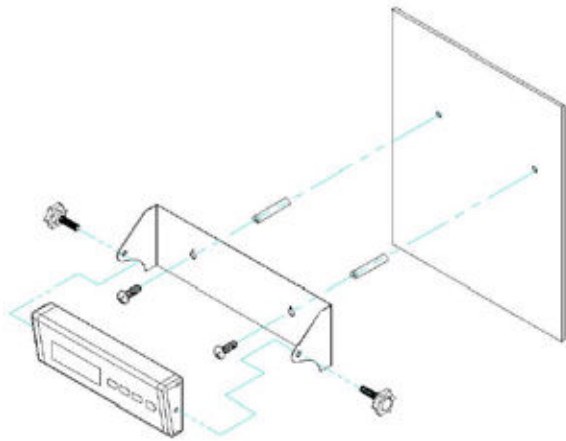

YOUR SCALE IS NOW READY FOR USE.

Display and Function

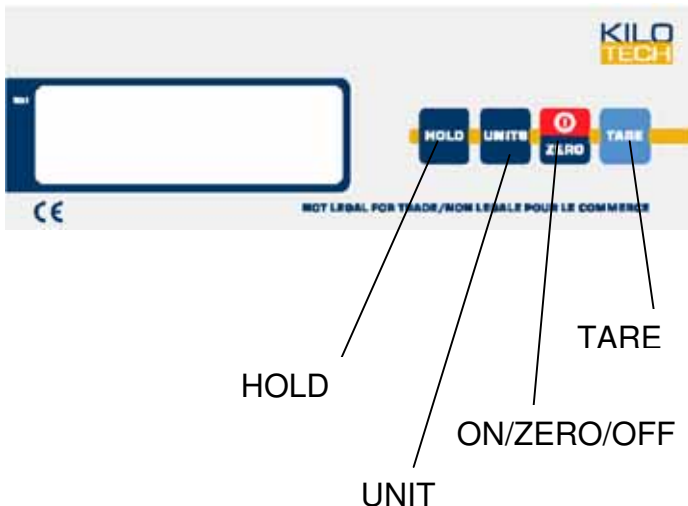

General Operation

POWER ON

To turn the scale on, press the button marked "ON/ZERO/OFF". The display will first show "8888" for approximately two (2) seconds, then display "00". This indicates that the scale is ready for use.

WEIGHING

When the display shows "00" it is ready to weigh an object. If the object exceeds the capacity of the scale by more than 5%, the display will show "0000,".

Until the overload condition is reached, objects can be placed on the platform, with the display showing the total weight of all objects on the platform.

TARE OPERATION

To tare (zero out) a load on the platform (i.e.: the weight of a container), press the button marked "TARE" one time. When this is done, the display will show the value "00". This could be followed by the addition of another load, if so desired. The display will show the sum of all additional loads above and beyond the tared load.

TARE CAPABILITY

A load of up to the capacity of the scale can be tared (zeroed out).

When a load is tared, an additional load up to the full capacity of the scale can be weighed.

Example: A Model 50 has a capacity of 50 kgs if a load of 10kgs on that scale is tared (zeroed out), an additional load or loads of up to 40 kgs can be weighed.

TO HOLD THE WEIGHT DISPLAY

To hold the weight display, press the HOLD key. The weight will be held until the TARE key or HOLD key is pressed again.

NOTICE:

Use this device ONLY for its intended use. Consult www.kilotech.com for more details.

Error and Status Messages

Low Battery

If battery is discharged, the display will show the