

Label Printing Scale

CL7200 series



Touch Screen Label Printing Scale

Designed for weighing and label printing in supermarkets, groceries, and other retail stores, the CAS CL7200 Touch Screen Label Printing Scale, delivers crisp, easy to read labels for all users. Graphics are rich & colorful with the responsive 10.2-inch touch display.

Measurement
Canada *Approved*



CAS

CL7200 Series

10.2" LCD Touch Screen

Full color 10.2" TFT LCD display presents pictures and PLUs vividly with minimal reflections. Responsive smart touch features provides easy navigation for quick access to any PLU call up.

7" Display for Customers

The 7-inch TFT LCD customer side display provides vivid full color graphics complete with audio. Display images or video for your customers. Perfect for advertisements or brand awareness campaigns.



PLUs

The CL7200 Touch Screen Label Printing Scale comes standard with 72 PLU keys on the home panel. Customize the PLU keys to suit your needs. Add product images or use simple text. Add additional PLU keys or Category Keys, change sizes, or add more PLU key pages within category.

PLU's can be set up directly in the scale using the intuitive interface or created using CL Works Pro software.

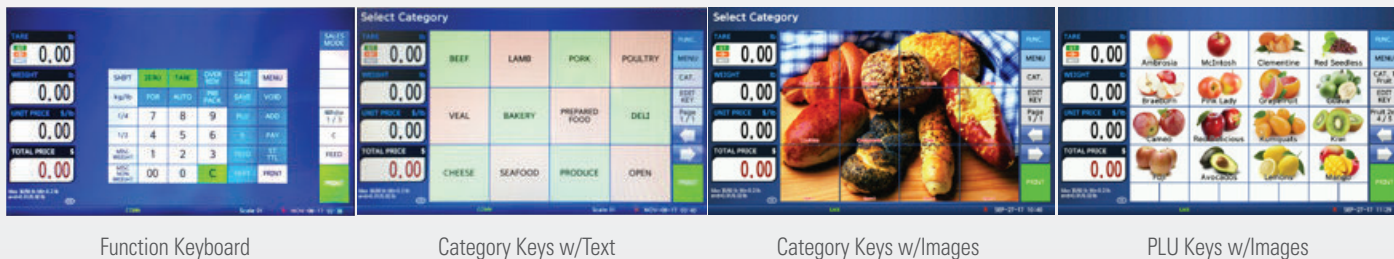

Function Keyboard

Category Keys w/Text

Category Keys w/Images

PLU Keys w/Images

Integrated Printer

The CAS CL7200 is equipped with an integrated direct thermal printer that produces clear 202 dpi label printing with printing speeds up to 100mm/sec. Various die cut or continuous label sizes can be used up to 60 mm (56 mm printable) wide and 200 mm in length.



Quickly & Easily Change Labels

Simply replace your labels with the removable, easy-to-use label cassette - takes only a few seconds to complete. The label cassette access door is conveniently located at the side of the scale, designed for quick label roll replacement.

Labels

45 Standard Labels • 20 Custom Labels Available Printed Elements

- Vertical Barcodes
- Ingredients
- Nutrition Facts
- Sales Discounts
- Graphics
- Multiple Languages
- And More!

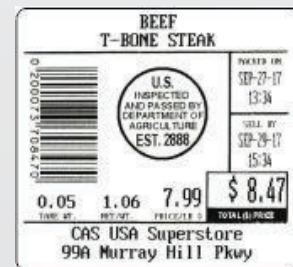

Touchscreen Label Printing Scale

Software

CL-Works Pro



Data Editing

CL-Works Pro offers an easy-to-use data editing solution for businesses in supermarkets, grocery stores, delicatessens, and other retail markets. Manage all retail activities from PLUs to label formats.

Data Analysis

CL-Works Pro provides solution for analyzing sales data quickly, easily and accurately. The accumulated data would become an asset for users who want to get deeper insights from the data in order to make better predictions.

Compatibility

CL-Works Pro is compatible with all CL Series Label Printing Scales that use the most recent firmware. Control multiple scales remotely and efficiently manage your retail process.

- Easy PLU management control for all scales
- Simple PLU import & export
- Manage PLU's in multiple departments
- Supports WEP, WPA, & WPA2 Encryption

Networking Capabilities



- TCP/IP Communications
- 100 Base T Ethernet
- IEEE 802.11 g/n Wireless

Compatible Popular Scale Management Software Packages*

If you use either Applied Data Corporation's InterScale Scales Manager or Invatron's E-Plum to manage your scales, then you can easily add the CAS CL Family of Label Printing Scales to your network!*



*E-Plum Scale Management Software is owned and sold by Invatron Systems Corp. For more information, please visit www.invatron.com. InterScale Scales Manager is owned and sold by Applied Data Corporation. For more information, please visit www.applieddatacorp.com.

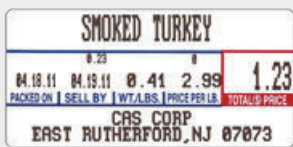

SPECIFICATIONS

MODEL	CL7200-30(W)	CL7200-60(W)
Max. Capacity	15 kg/30 lb	30 kg/60 lb
Weighing Capacity	15 kg / 30 lb Capacity Dual Range 0 - 15 x 0.005 lbs / 15 - 30 x 0.01 lbs 0 - 6 x 0.002 kg / 6 - 15 x 0.005 kg	
	30 kg / 60 lb Capacity Dual Range 0 - 30 x 0.01 lbs / 30 - 60 x 0.02 lbs 0 - 15 kg x 0.005 kg / 15 - 30 kg x 0.01 kg	
Max Tare	6 kg/15 lb	15 kg/30 lb
A/D Conversion Rate	Approx. 8 times/sec.	
Measurement Type	Load Cell	
Platter Size	15 in x 9.75 in / 380 mm x 250 mm	
Key	99 Category Keys - 20 Speed Key Pages/Category available - Max 72 1x1 Size Keys/Page - 36 Function Keys	
Units	lb/kg	
Display	Operator	Customer
	10.2 inch Graphic Touch LCD Tare : 4 digit Weight : 5 digit Unit Price : 6 digit Total Price : 6 digit	7 inch Graphic LCD Tare : 4 digit Weight : 5 digit Unit Price : 6 digit Total Price : 6 digit
Print Speed	100 mm/sec	
Print Resolution	202 dpi	
Label Size	Width: 40 mm-60 mm Length: 30 mm-200 mm	
Barcode	UPC, EAN13, EAN13A5, I2OF5, CODE128, CODE39, CODE93, CODABAR	
Font	Small, Middle, Large Size, Italic, Bold, Underline, Through Line, Reverse	
Printer Type	Direct Thermal Print	
Operating Temp	-10°C ~ 40°C (14°F ~ 104°F)	
Power	AC 100 ~ 240V 50/60Hz 1.5A	
MODEL	CL7200RP-60 Remote Platform	CL7200RP-300 Remote Platform
Max. Capacity	30 kg/60 lb	150 kg/300 lb
Weighing Capacity	30 kg/60 lb Capacity Dual Range 0 - 30 x 0.01 lbs / 30 - 60 x 0.02 lbs 0 - 15 kg x 0.005 kg / 15 - 30 kg x 0.01 kg	
	150 kg/300 lb Capacity Dual Range 0 - 150 x 0.05 lbs / 150 - 300 x 0.1 lbs 0 - 60 x 0.02 kg / 60 - 150 x 0.05 kg	
Max Tare	15 kg/30 lb	60 kg/150lb
Platter Size	20.25 in x 15.5 in / 515 mm x 395 mm	

Options

- Fish Pan
- Remote Platform
- Label Cartridge



Features

- 30 lb & 60 lb Models - Dual Range
- 60 lb & 300 lb Remote Platforms
- 4,000 PLU's with Direct Ingredient Message in PLU data file
- 45 Standard Label Formats/20 Custom Label Formats
- High Speed Thermal Printer
- USB or PC Firmware Upgrades
- USB Program Back-up and Restore
- Multiple barcode formats
- **Ethernet/Wireless Network Capabilities Built-in**
- English or Spanish Characters
- CL Series Menu Code System
- Remote Access for Support / Built-in Diagnostics
- Works with CL-Works Pro Software Package
PLU Editor - Label Editor - Keypad Editor
Compatible with Microsoft Windows® 10
- Works with Invatron's E-PLUM Scale Management and ADC's
InterScale Scales Manager software
- Approvals - NTEP COC # 17-096
Measurement Canada - AM-6087

DIMENSIONS

Units: inches/mm

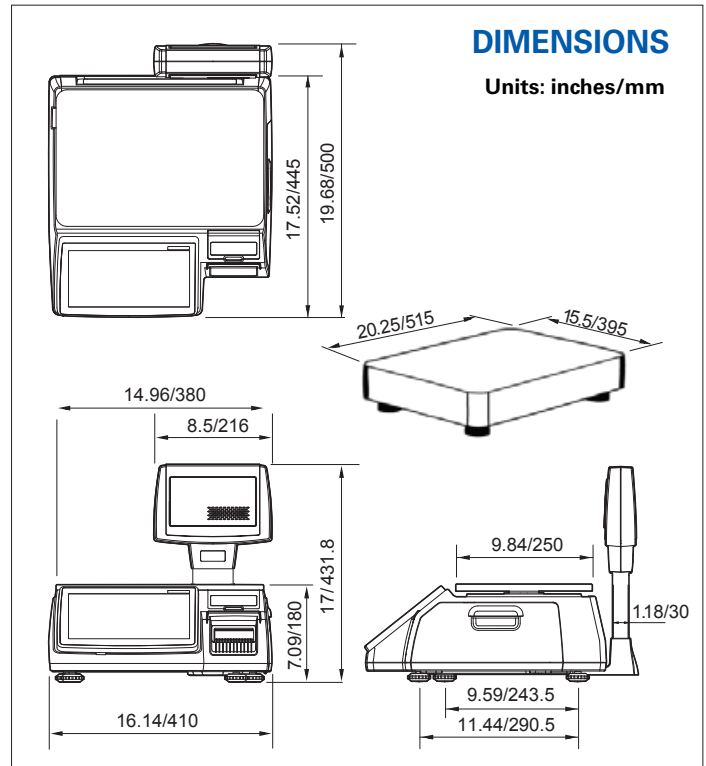

v91024020



Specifications are subject to change without notice improvement.

99 Murray Hill Pkwy Unit A
East Rutherford, NJ 07073
800.223.4227 / 201.933.9002

www.cas-usa.com

CAS